

10. Electrical connections

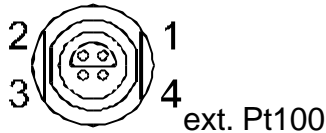

Notice:

Use shielded cables only.
The shield of the connecting cable is electrically connected to the plug housing.



Socket for external Pt100 sensor

Pin assignment:

Pin	Signal
1	I+
2	U+
3	U-
4	I-

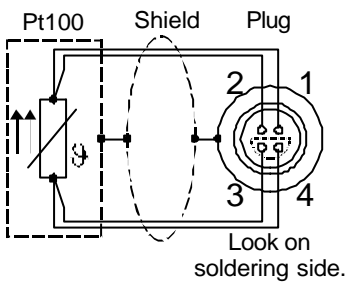

The shield of the connecting cable is electrically connected to the plug housing and the sensor tube.

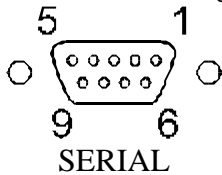

RS232/RS485 serial interface (20)

This port can be used to connect a computer with an RS232 or RS485 cable for remote control of the circulator.

Pin assignments RS232:

Pin 2	RxD	Receive Data
Pin 3	TxD	Transmit Data
Pin 5	0 VD	Signal GND
Pin 6	DTR	Data terminal ready
Pin 7	RTS	Request to send
Pin 8	CTS	Clear to send

Pin assignments RS485:

Pin 3	A	
Pin 5	0 VD	Signal GND
Pin 8	B	

Pins 1; 2; 6; 7; 9 are reserved - do not use!

Interface correspondence: RS232:

Circulator 9-pole		PC 25-pole		Circulator 9-pole		PC 9-pole
Pin 2 RxD	⇔	Pin 2 TxD		Pin 2 RxD	⇔	Pin 3 TxD
Pin 3 TxD	⇔	Pin 3 RxD		Pin 3 TxD	⇔	Pin 2 RxD
Pin 5 GND	⇔	Pin 7 GND		Pin 5 GND	⇔	Pin 5 GND
Pin 6 DTR	⇔	Pin 6 DSR		Pin 6 DTR	⇔	Pin 6 DSR
Pin 7 RTS	⇔	Pin 5 CTS		Pin 7 RTS	⇔	Pin 8 CTS
Pin 8 CTS	⇔	Pin 4 RTS		Pin 8 CTS	⇔	Pin 7 RTS

RS232 interface cable 9-pin / 9-pin, 2.5 m - Order No.: 8 980 073

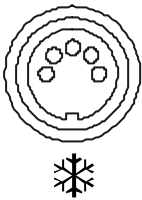

❄ / Control output

The ❄ connector may be used for control of JULABO refrigerated circulators or as output for alarm messages.

Circuit: Operation = relay powered
 Alarm = relay not powered

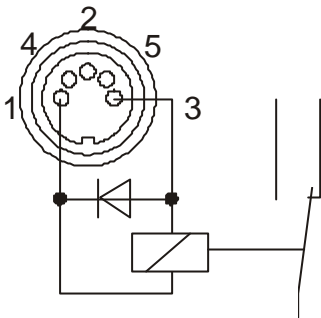

Pin assignment:

Pin	Signal
1	+24 V (I max. current 25 mA)
2	0 V
3	Alarm relay
4	Reserved - do not use!
5	Cooling pulse

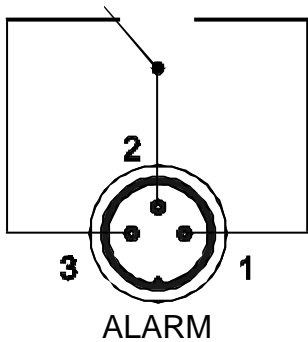

Alarm output

(for external alarm signal)

This potential-free change-over contact is activated in case of an alarm when pins 2 and 3 are connected.

Switching capacity max. 30 W / 40 VA
 Switching voltage max. 125 V~/–
 Switching current max. 1 A

Functional description see page 57

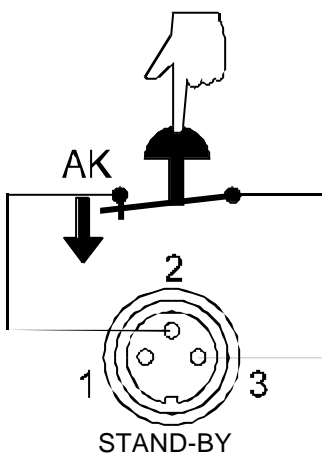

STAND-BY input

(for external emergency switch-off)

Pin assignment:

Pin	Signal
1	not connected
2	5 V / DC
3	0 V

Functional description see page 58

Programmer input / temperature recorder output

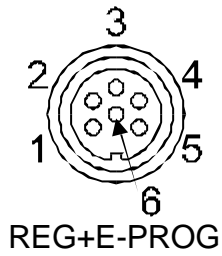

Pin	Signal
1 Voltage output	Channel 1 0 ... 10 V
2 Voltage output	Channel 2 0 ... 10 V
3 GND for outputs	0 V
4 Programmer input	EPROG 0 to 10 V / 0 to 20 mA
5 Current output	Channel 3 0 to 20 mA / 4 to 20 mA
6 GND for Programer	0 V

Functional description see page 59

11. Remote control

11.1. Setup for remote control

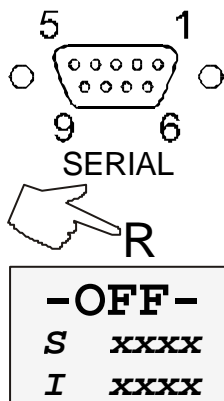

1. Check the interface parameters for both interfaces (on circulator and PC) and make sure they match.
(Serial interface see page 45)
2. In the menu > MENU / CONFIG < set the menu item > SETPoint < to > SERIAL < .
(see 7.3.1. SETPOINT – Keypad control or remote control on page 40)
3. Connect both units with an interface cable..



Like all parameters which can be entered through the keypad, interface parameters are stored in memory even after the circulator is turned off.