

1. Electrical connections

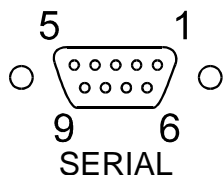

RS232/RS485 serial interface (30)

This port can be used to connect a computer with an RS232 or RS485 cable for remote control of the circulator.







Pin assignments: RS232

Pin 2	RxD	Receive Data
Pin 3	TxD	Transmit Data
Pin 5	0 VD	Signal GND
Pin 6	DTR	Data terminal ready
Pin 7	RTS	Request to send
Pin 8	CTS	Clear to send

Pin assignments: RS485

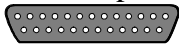
Pin 3	A	
Pin 5	0 VD	Signal GND
Pin 8	B	
Pins 1, 2, 4, 6, 7, 9		Reserved - do not use!

Interface correspondence:

Circulator		Computer		Circulator		Computer
						
9-pole		25-pole		9-pole		9-pole
Pin 2 RxD	↔	Pin 2 TxD		Pin 2 RxD	↔	Pin 3 TxD
Pin 3 TxD	↔	Pin 3 RxD		Pin 3 TxD	↔	Pin 2 RxD
Pin 5 GND	↔	Pin 7 GND		Pin 5 GND	↔	Pin 5 GND
Pin 6 DTR	↔	Pin 6 DSR				
Pin 7 RTS	↔	Pin 5 CTS		Pin 7 RTS	↔	Pin 8 CTS
Pin 8 CTS	↔	Pin 4 RTS		Pin 8 CTS	↔	Pin 7 RTS

RS232 interface cable 9-pin / 9-pin, 2,5 m

Order No.: 8 980 073



If the circulator is put into remote control mode via the configuration level, the display will read "r OFF" = REMOTE STOP.

The circulator is now operated via the computer.

In general, the computer (master) sends commands to the circulator (slave). The circulator sends data (including error messages) only when the computer sends a query.

A transfer sequence consists of:

- address (RS485 interface only)
- command
- space (↔ Hex: 20)
- parameter (the character separating decimals in a group is the period)
- end of file (↵; Hex: 0D)

The commands are divided into **in** or **out** commands.

in commands: asking for parameters to be displayed

out commands: setting parameters

The **out** commands are valid only in remote control mode.



When the RS485 interface is used, the three-digit instrument address stands in front of each command.

(example: address Ad32 = **A032**)

Examples:

Command to set the working temperature T to 55.5 °C

out_sp_00 ↔ 55.5↵

A032_out_sp_00 ↔ 55.5↵

Command to ask for the working temperature T:

in_sp_00↵

A032_in_sp_00↵

Response from the circulator:



55.5↵

A032_55.5↵

1.1. List of commands

When the RS485 interface is used, the instrument address stands in front of each command (Axxx_).



in-commands: Asking for parameters or temperature values to be displayed.

version	none	Number of software version (V X.xx)
status	none	Status message, error message (see page 7)
in_pv_00	none	Actual bath temperature.
in_pv_01	none	Heating power being used (%).
in_pv_02	none	Temperature value registered by the external Pt100 sensor.
in_pv_03	none	Temperature value registered by the safety sensor.
in_pv_04	1 ... 8	Liquid level indication.
in_pv_05	none	Temperature value registered by the safety sensor 1
in_pv_06	none	Temperature value registered by the safety sensor 2 (only HT60)
in_pv_07	none	Temperature value registered by the safety sensor 3 (only HT60)
in_sp_00	none	Working temperature "T"
in_sp_03	none	High temperature warning limit "  ".
in_sp_04	none	Low temperature warning limit "  ".
in_sp_05	none	Setpoint temperature of the external programmer (socket 31 - REG+E-PROG) .
in_hil_00	none	Max. cooling power (%).
in_hil_01	none	Max. heating power (%).
in_mode_02	none	Identification type: 0 = no identification 1 = single identification 2 = continual identification

in-commands: Asking for parameters or temperature values to be displayed.

Command	Parameter	Response of circulator
in_mode_03	none	Type of the programmer input: 0 = Voltage 0 V to 10 V 1 = Current 0 mA to 20 mA
in_mode_04	none	Internal/external temperature control: 0 = Temperature control in the circulator bath. 1 = Temperature control with external Pt100 sensor.
in_mode_05	none	Circulator in Stop/Start condition: 0 = Stop 1 = Start
in_par_01	none	Time constant of the external bath.
in_par_02	none	Internal slope.
in_par_03	none	Time constant of the internal bath.
in_par_04	none	Band limiting (max. difference between the temperatures in the internal bath and external system).
in_par_06	none	Xp control parameter of the internal controller.
in_par_07	none	Tn control parameter of the internal controller.
in_par_08	none	Tv control parameter of the internal controller.
in_par_09	none	Xp control parameter of the cascade controller.
in_par_10	none	Proportional portion of the cascade controller.
in_par_11	none	Tn control parameter of the cascade controller.
in_par_12	none	Tv control parameter of the cascade controller.



out commands: Setting parameters or temperature values.

Command	Parameter	Response of circulator
out_mode_02	0	No identification. Temperature control by using the stored parameters.
out_mode_02	1	Single identification of controlled system after the next start.
out_mode_02	2	Continual identification of controlled system whenever a new setpoint is to be reached.
out_mode_04	0	Temperature control of internal bath.
out_mode_04	1	External control with Pt100 sensor.
out_mode_05	0	Stop the circulator = r OFF.
out_mode_05	1	Start the circulator.
out_sp_00	xxx.x	Set working temperature "T".
out_sp_03	xxx.x	Set high temperature warning limit  .
out_sp_04	xxx.x	Set low temperature warning limit  .
out_hil_00	xxx	Set the desired maximum cooling power (0 % to 100 %). This adjustment is required only for proportionally controlled refrigerated circulators.
out_hil_01	xxx	Set the desired maximum heating power (10 % to 100 %).
out_par_04	xxx	Band limiting during external control. Setting the maximum difference between the temperatures in the internal bath and external system.
out_par_05	xxx	Ratio for max. cooling power versus max. heating power (0...0.99).
out_par_06	xxx	Xp control parameter of the internal controller.
out_par_07	xxx	Tn control parameter of the internal controller.
out_par_08	xxx	Tv control parameter of the internal controller.
out_par_09	xxx	Xp control parameter of the cascade controller.
out_par_10	xxx	Proportional portion of the cascade controller.
out_par_11	xxx	Tn control parameter of the cascade controller.
out_par_12	xxx	Tv control parameter of the cascade controller.

1.2. Status messages / error messages

The circulator sends data (including error messages) only when the computer sends a query.

Status messages	Description
00 MANUAL STOP	Circulator in "OFF" state.
01 MANUAL START	Circulator in keypad control mode.
02 REMOTE STOP	Circulator in "r OFF" state.
03 REMOTE START	Circulator in remote control mode.

Error messages	Description
-01 LOW LEVEL ALARM	Low liquid level alarm
-03 EXCESS TEMPERATURE WARNING	High temperature warning "  ".
-04 LOW TEMPERATURE WARNING	Low temperature warning "  ".
-05 WORKING SENSOR ALARM	Working temperature sensor short-circuited or interrupted.
-06 SENSOR DIFFERENCE ALARM	Sensor difference alarm. Working temperature and safety sensors report a temperature difference of more than 25 °C.
-07 I²C-BUS ERROR	Internal error when reading or writing the I ² C bus.
-08 INVALID COMMAND	Invalid command.
-09 COMMAND NOT ALLOWED IN CURRENT OPERATING MODE	Invalid command in current operating mode.
-10 VALUE TOO SMALL	Entered value too small.
-11 VALUE TOO LARGE	Entered value too large.
-12 TEMPERATURE MEASUREMENT ALARM	Error in A/D converter.
-13 WARNING : VALUE EXCEEDS TEMPERATURE LIMITS	Value lies outside the adjusted range for the high and low temperature warning limits. But value is stored.

Error messages	Description
-14 TEMPERATURE/LEVEL ALARM	Safety temperature alarm 
-15 EXTERNAL SENSOR ALARM	External control selected, but external Pt100 sensor not connected.
-19 TEMPERATUR MEASUREMENT ALARM	Error in the measuring system of the external temperature sensor „EXT“
-26 STAND-BY PLUG IS MISSING	External stand-by contact is open. Stand-by input - see pages and Error! Bookmark not defined..
-31 INTERNAL COMMUNICATION ERROR	Communication between circulator HTxx and the control electronics Mx.
-33 SAFETY SENSOR 1 ALARM	Safety sensor 1: Cable of the safety sensor 1 interrupted or short-circuited.
-34 SAFETY SENSOR 2 ALARM	Safety sensor 2: Cable of the safety sensor 2 interrupted or short-circuited.
-35 SAFETY SENSOR 3 ALARM	Safety sensor 3: Cable of the safety sensor 3 interrupted or short-circuited.
-36 SENSOR COOLING ZONE ALARM	Safety sensor in the cooling zone: Cable of the safety sensor interrupted or short-circuited.
-37 INTERNAL ALARM	Safety sensor in the cooling zone: The temperature in the cooling zone has exceeded 130 °C!